

Mathematical Model of the Respiratory System – Comparison of the Total Lung Impedance in the Adult and Neonatal Lung

M. Rozanek, and K. Roubik

Abstract—A mathematical model of the respiratory system is introduced in this study. Geometrical dimensions of the respiratory system were used to compute the acoustic properties of the respiratory system using the electro-acoustic analogy. The effect of the geometrical proportions of the respiratory system is observed in the paper.

Keywords—Electro-acoustic analogy, total lung impedance, mechanical parameters, respiratory system.

I. INTRODUCTION

ONE of the common pulmonary diseases is adult respiratory distress syndrome (ARDS). A lot of patients suffering by ARDS require use of artificial lung ventilation (ALV). ALV is the most efficient method for treatment of acute respiratory failure. There are many regimens of artificial lung ventilation and other protective ventilatory modes are introduced. Despite this fact, there are still strong adverse effects of artificial ventilation upon patient's respiratory system. The modern trend is to minimize the risk of the respiratory system impairment.

Ventilatory strategy called high frequency ventilation (HFV) is one of the new ventilatory techniques. Ventilatory frequency is increased during HFV. Frequency rate is in range 10-25 Hz. This increase of the ventilatory frequency allows a significant decrease in pressure amplitude and delivered tidal volume. Usage of the small pressure amplitudes in the airways and breathing with very low tidal volumes prevent the lungs from overdistension, barotrauma and volutrauma. The difference in the frequency, pressure and tidal volume represent the most significant difference between HFV and conventional artificial lung ventilation (CV).

Different effects of artificial ventilation can be observed when conventional ventilation (CV) or high frequency ventilation (HFV) is used. Many parameters can influence the oxygenation, but their effect is mostly impossible to study directly in the human body. Therefore, design of the model of the respiratory system exactly corresponding with the reality can be the only possibility how to study influence of mechanical, geometrical and other lung properties through the bronchial tree. A unique modelling approach has been chosen in this study based on the respiratory system modelling according to its exact anatomical structure. Geometrical

dimensions of the adult and neonatal human lung were used to compare the total impedance of the respiratory system. Effect of the ventilatory frequency is studied.

II. METHODS

The aim of this study was to design the model of the human respiratory system with respect to its anatomical structure. The model is computed from the morphological geometrical proportions of the respiratory system [1]. The model has a similar structure as a respiratory system. A very complex structure of the human respiratory system begins with trachea and divides with each generation of the structure by course of irregular dichotomy. Therefore the tubes have various length and diameter in the same generation of the lung structure. Whole human lung structure can be seen in Fig. 1.

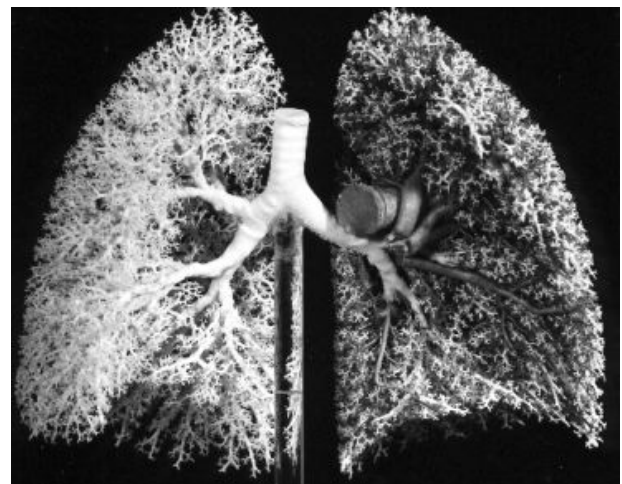

Fig. 1 Anatomical structure of the respiratory system. Reprinted from [2]

It would be very difficult to work with so difficult structure; therefore morphological models of the respiratory system were introduced [3]. The models neglect very often the irregularity in the airway branching. Therefore airways are dividing by course of regular dichotomy. Then the tubes have the same length and diameter in the same generation in this model. The Weibel's morphological model [1]-[3] has been used to design mathematical model of the respiratory system that respect the anatomy of the respiratory system.

The respiratory system can be considered as an acoustic system. All individual airways correspond to short acoustic

wave-guides computed using the common acoustic principles and the published lung morphometry measurements [1]-[3]. The geometrical proportions of the morphological model of the adult human lung can be seen in Table I.

TABLE I

GEOMETRICAL PROPORTIONS OF THE ADULT AIRWAY MODEL (AVERAGE ADULT HUMAN LUNG WITH THE LUNG VOLUME OF 4800 ML, 3/4 OF THE TOTAL LUNG CAPACITY APPROXIMATELY): GENERATION IS DENOTED AS Z, AIRWAY NUMBER IN GENERATION N(Z), AIRWAY DIAMETER D(Z), AIRWAY LENGTH L(Z) [1]

z	n(z)	d(z) [cm]	l(z) [cm]
0	1	1,8	12
1	2	1,22	4,76
2	4	0,83	1,9
3	8	0,56	2,76
4	16	0,45	1,27
5	32	0,35	1,07
6	64	0,28	0,9
7	128	0,23	0,76
8	256	0,186	0,64
9	512	0,154	0,54
10	1024	0,13	0,46
11	2048	0,109	0,39
12	4096	0,095	0,33
13	8192	0,082	0,27
14	16384	0,074	0,23
15	32768	0,066	0,2
16	65536	0,06	0,165
17	131072	0,054	0,141
18	262144	0,05	0,117
19	524288	0,047	0,099
20	1048576	0,045	0,083
21	2097152	0,043	0,07
22	4194304	0,041	0,059
23	8388608	0,041	0,05

The geometrical proportions of the morphological model of the neonatal lung can be seen in Table II.

TABLE II

GEOMETRICAL PROPORTIONS OF THE NEONATAL AIRWAY MODEL: GENERATION IS DENOTED AS Z, AIRWAY NUMBER IN GENERATION N(Z), AIRWAY DIAMETER D(Z), AIRWAY LENGTH L(Z) [1]

z	n(z)	d(z) [cm]	l(z) [cm]
0	1	0,539	3,594
1	2	0,365	1,426
2	4	0,249	0,569
3	8	0,143	0,195
4	16	0,115	0,325
5	32	0,090	0,274
6	64	0,072	0,230
7	128	0,059	0,195
8	256	0,048	0,164
9	512	0,039	0,138
10	1024	0,033	0,118
11	2048	0,028	0,100
12	4096	0,024	0,084
13	8192	0,021	0,069
14	16384	0,019	0,059
15	32768	0,017	0,051
16	65536	0,015	0,042
17	131072	0,014	0,036
18	262144	0,013	0,030
19	524288	0,012	0,025
20	1048576	0,012	0,021
21	2097152	0,011	0,018
22	4194304	0,010	0,015
23	8388608	0,010	0,013

An electro-acoustic [4] analogy was used to develop an electric model of the respiratory system respecting its exact anatomical structure. Acoustic inertance m_a , acoustic compliance c_a and acoustic resistance r_a can be computed according to the functions (1), (2) a (3) [4]:

$$m_a = \frac{\rho_0 l}{S}, \quad (1)$$

$$c_a = \frac{V}{\rho_0 c_0^2}, \quad (2)$$

$$r_a = \frac{8\mu l}{\pi R_t^4}, \quad (3)$$

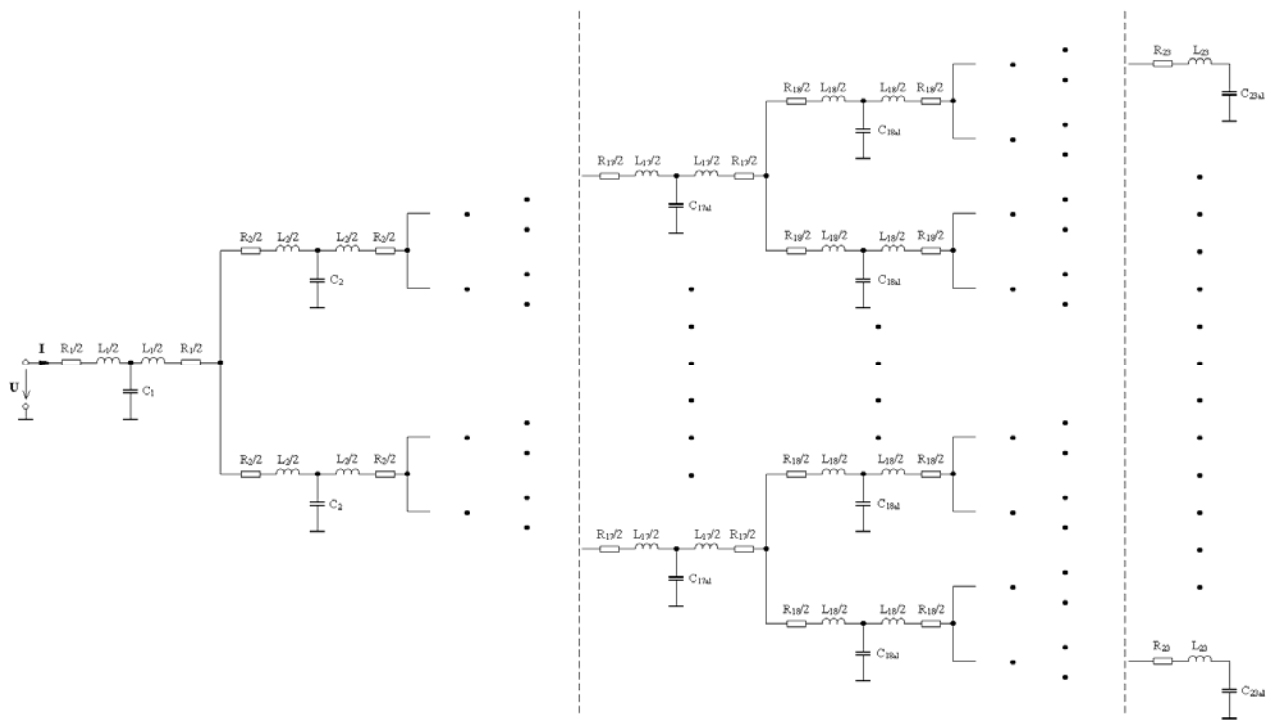

Fig. 2 Model of the respiratory system

where ρ_0 stands for air density, l stands for length, S stands for cross-sectional area, V stands for volume, c_0 stands for propagation velocity, μ stands for air viscosity and R_i stands for diameter of the tube.

Computed acoustic parameters describe elementary acoustic tubes. Therefore, the final model has 23 airway generations as morphological model and it employs 67 108 859 individual components. The complete electrical model of the human respiratory system is shown in Fig. 2.

III. RESULTS

Total lung impedance was computed for the adult lung (Fig. 3). The resonant frequency is approximately $f_r = 3$ Hz. The frequencies used during HFV are close to f_r . The impedance is higher for the frequencies that correspond to the use of CV.

The dependence of the total lung impedance of the neonatal lung upon the frequency has a different character contrary to adult lung. The chart is shown in Fig. 4. The impedance is higher according to smaller proportions of the lung and it is difficult to determine f_r .

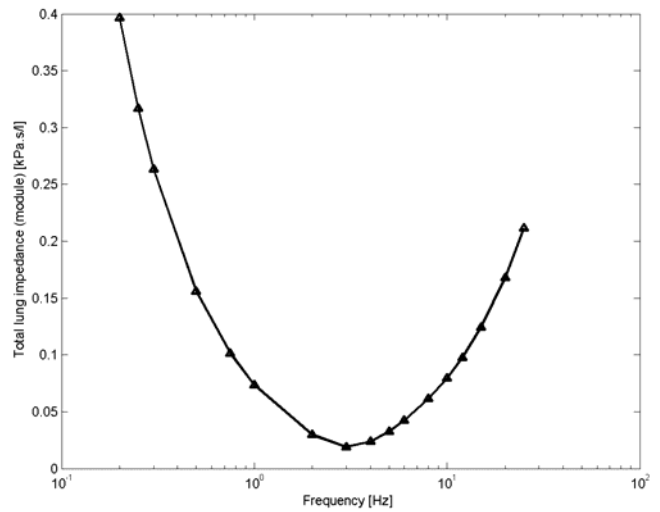

Fig. 3 Dependence of the total lung impedance of the adult lung upon the ventilatory frequency

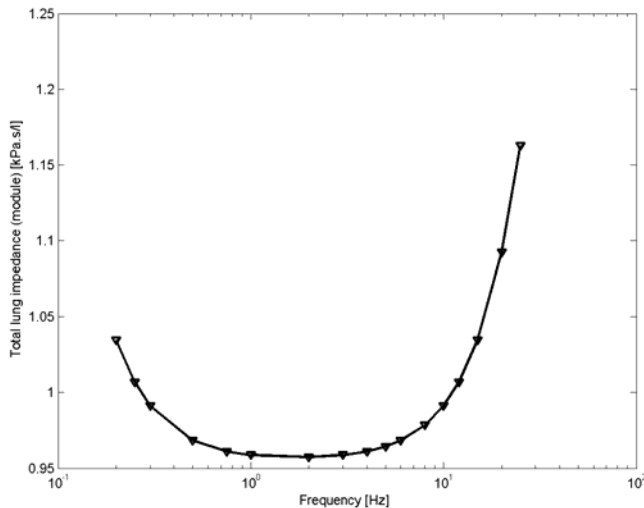

Fig. 4 Dependence of the total lung impedance of the neonatal lung upon the ventilatory frequency

IV. CONCLUSION

A unique model of the respiratory system has been developed and designed. It is possible to study the effects of the geometrical proportions of the airways on the parameters that can influence the efficiency of ALV. The model also allows study the intrapulmonary conditions during different mechanical parameters of the respiratory system. The mechanical properties of the lung tissue are changed during ARDS [5]. The type of change is dependent upon the origin of ARDS [6]. It is possible to use this model to observe the efficiency of the elementary ventilatory strategies during different mechanical properties of the respiratory system and choose the optimal ventilation therapy. The simulations proved significant effect of the mechanical properties of the respiratory system upon the intrapulmonary conditions.

ACKNOWLEDGMENT

This research work has been supported by the research program No. MSM6840770012.

REFERENCES

- [1] E. R. Weibel, *Morphometry of the human lung*. Berlin: Springer-Verlag, 1963.
- [2] T.W. Shields, J LoCicero, R.B. Ponn, *General Thoracic Surgery*. 5th edition, Philadelphia: Lippincott Williams & Wilkins, 2000.
- [3] F.H.C. de Jongh, *Ventilation modelling of the human lung*. Delft: Delft University of technology, 1995.
- [4] Z. Škvor, *Akustika a elektroakustika*. Prague: Academy of Science, 2001.
- [5] J.B. West, *Pulmonary Pathophysiology - the essentials*. 4th edition Baltimore: Williams & Wilkins, 1992.
- [6] P. Pelosi, D. D'Onofrio, D. Chiumello, S. Paolo, G. Chiara, V.L. Capelozzi, C.S.V. Barbas, M. Chiaranda, L. Gattinoni: *Pulmonary and extrapulmonary acute respiratory distress syndrome are different*. Eur Respir J 2003; 22:48S-56S.